

IsoFlex™

MINIMIZING

VIBRATION

MINIMIZING VIBRATION



APPLICATIONS: MARINE

DEFENSE

INDUSTRIAL

COMMERCIAL

SEISMIC

GEARguard

FLEX COUPLINGS

INSTALL A FLEXIBLE COUPLING IF YOU WANT TO:

- Reduce the chance of damage to your engine and transmission. Under normal circumstances, a sacrificial flexible coupling should fail before this damage occurs.
- Isolate and minimize drive line vibration, propeller pulse and gear chatter. The result is a much quieter boating experience.
- Enhance drive bearing service life by reducing wear.
- Assist engine mounts to do their job by allowing controlled engine movement.
- Help alleviate thrust-induced drive line misalignment.

GEARguard

FLEX COUPLINGS

INSTALL AN ISOFLEX GEARguard COUPLING BECAUSE:

- IsoFlex has developed a specialized machining technique to eliminate run-out and consequent vibration.
- With IsoFlex internal hex-shaped fittings, the possibility of inserts turning in the coupling is minimized.
- IsoFlex couplings are easy to install. No cutting is required and your boat can remain in the water.
- IsoFlex takes the guesswork out of selecting the right coupling for your application. Please follow the “How to Measure” instructions beginning on page 5.
- Most 8-Bolt, 10-Bolt and large 6-Bolt couplings have been designed with precision machined steel index rings which maximize dimensional stability and minimize run-out.

CATALOG

CONTENTS

I have a coupling I would like to replace.

Please turn to pages 18 through 20 for cross reference charts.

Here you will find the correct GEARguard coupling to replace a Globe DriveSaver and other commonly used couplings.

I have my transmission information. Which coupling do I need?

Please turn to pages 21 through 24 for cross reference charts.

Here you will find the correct GEARguard coupling to use with a variety of transmissions, organized by manufacturer.

Will it fit?

If you do not find a cross reference “fit”, please turn to pages 5 through 9 for step-by-step measurement instructions.

Once you have completed this information describing your gearbox flange, you can refer to page 10 for 4-Bolt coupling information, page 12 for 6-Bolt coupling information, page 14 for 8-Bolt coupling information and page 16 for 10-Bolt coupling information. Information about Spicer U-Joint couplings can be found on page 17.

Will it work?

IsoFlex Technologies strongly suggests that you calculate the torque rating for your specific installation.

Please turn to pages 7 and 8 for instructions on how to calculate the torque rating of your current drive train.

Then proceed to page 11 for the corresponding torque ratings of IsoFlex 4-Bolt couplings, page 13 for 6-Bolt torque rating, page 15 for 8-Bolt couplings and page 16 for 10-Bolt.

As long as your torque rating is less than or equal to that of the IsoFlex coupling you wish to order, your IsoFlex product should work perfectly. If your torque exceeds that of the posted IsoFlex rating for your coupling, please contact IsoFlex or your local distributor to discuss a custom coupling.

How do I install it?

Please turn to pages 25 through 29 to read a general set of installation instructions. Instructions specific to your IsoFlex GEARguard coupling are included with each product.

GEARguard

FLEX COUPLINGS

HOW TO MEASURE:

1

1. Bolt Circle Diameter:

2. Number of Bolt Holes

in the Gearbox Flange: _____

3. Size of Bolt Holes

in the Gearbox Flange: _____

Before ordering, you will need to examine your current *gearbox flange* and propeller shaft flange. In order to determine the following information, it will be necessary to remove all of the bolts from the flanges. Slide the propeller shaft flange aft of the *gearbox flange* approximately 50mm. All measurements are best taken with a caliper. (Record your findings in the measurement box on each page).

1. Bolt Circle Diameter - 4-Bolt, 6-Bolt and 8-Bolt Flanges

In each *gearbox flange*, you should find that the hole pattern aligns one hole directly across from another on the opposite side of the flange. Measure the outside edge of one hole to the inside edge of the hole directly across from it. This is the bolt circle diameter. It is always a good idea to measure two different sets of holes and compare results.

2. Count number of bolt holes in the *gearbox flange*.

3. Size of Bolt Holes in the Flange Diameter

Simply measure the inside diameter of one or more of the holes in the *gearbox flange* and record result here.

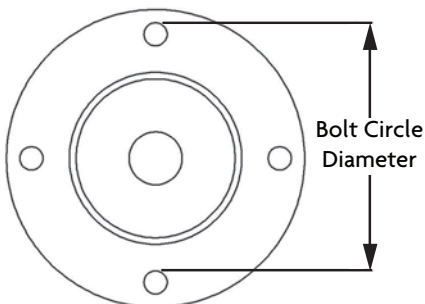

**4-Bolt
Gearbox Flange**

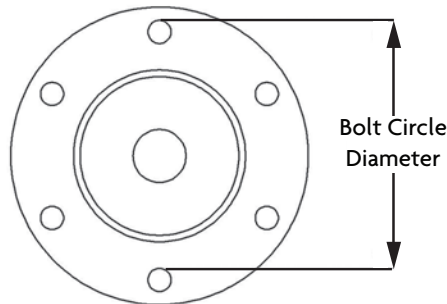

**6-Bolt
Gearbox Flange**

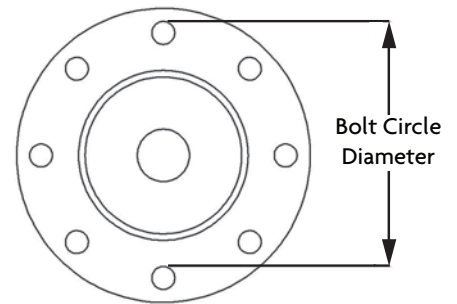

**8-Bolt
Gearbox Flange**

HOW TO MEASURE:

2

Gearbox Flange Index Ring Type -

Male or Female: _____

4. Gearbox Flange Index Ring Outside
Diameter/Male: _____

5. Gearbox Flange Index Ring Inside
Diameter/Female: _____

6. Propeller Shaft Flange Thickness:

4. Index/Spigot/ Pilot Diameter - Male

Using a caliper, measure the inside diameter of the metal index ring on the face of the *gearbox flange*.

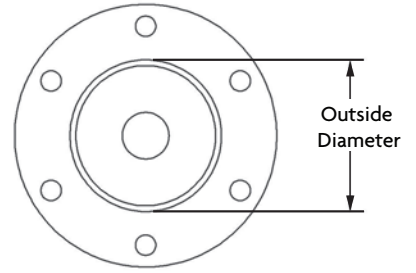

5. Index/Spigot/ Pilot Diameter - Female

Using a caliper, measure the inside diameter of the circular cavity in the center of the *gearbox flange*.

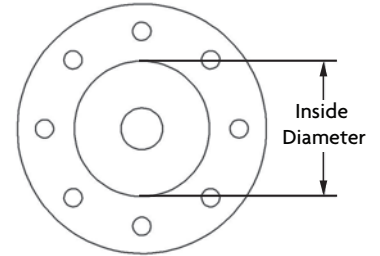

6. Propeller Shaft Flange Thickness

Using a caliper, measure the propeller shaft flange thickness at its edge. If the bolts you received with your coupling are too short for the flange thickness, please contact IsoFlex or your local distributor.

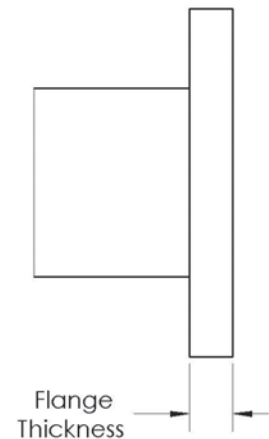

GEARguard

FLEX COUPLINGS

HOW TO MEASURE: 3

9. Drive Train Measurements:

A. Propeller clearance from rudder:

B. Propeller clearance from strut:

10. Maximum Torque Calculation:

Conversion factors:

1 ft-lb = 1.356 Nm	1 hp = 0.746 kW
1 Nm = 0.7376 ft-lb	1 kW = 1.34 hp

To determine the approximate engine/gearbox output torque in ft-lbs, use one of the formulae below:

$$\text{Torque (ft-lb)} = \frac{(\text{Engine power (hp)} \times 5252 \times \text{gear reduction ratio})}{\text{Engine RPM}}$$

$$\text{Torque (ft-lb)} = \frac{(\text{Engine power (kW)} \times 7038 \times \text{gear reduction ratio})}{\text{Engine RPM}}$$

$$\text{Torque (ft-lb)} = 0.737 \times \text{Torque (Nm)}$$

9. Drive Train Measurements

In some instances, the propeller shaft may have to be trimmed before installing the IsoFlex coupling. There are two reasons for this:

A. Propeller Clearance from Rudder

According to naval architecture guidelines, the rudder should be at least 20% of the propeller shaft diameter aft of the propeller for proper water flow off the prop and onto the rudder. This should minimize vibration and cavitation on the rudder.

B. Propeller Clearance from Strut

Just as important, the front end of the propeller should be no more than one shaft diameter aft of the strut. This is to prevent shaft vibration. The exposed shaft may be a bit longer to accommodate a shaft zinc, but that is all.

10. Torque Calculation

For the GEARguard coupling to work correctly, it must first be strong enough to meet the torque rating of your installation. That is, it must be able to carry the torque loads generated by the engine/transmission during normal operation.

Before installing any drive line coupling, you should first determine the “maximum allowable” torque rating of your engine/transmission. Published documentation for torque rating usually states the most conservative continuous torque rating. However, IsoFlex suggests that you take the time to calculate the rating for your specific installation.

Please use any of the formulae below to complete this calculation, noting the result in ft-lbs or Nm.

To determine the approximate engine/gearbox output torque in Nm, use one of the formulae below:

$$\text{Torque (Nm)} = \frac{(\text{Engine power (hp)} \times 7124 \times \text{gear reduction ratio})}{\text{Engine RPM}}$$

$$\text{Torque (Nm)} = \frac{(\text{Engine power (kW)} \times 9550 \times \text{gear reduction ratio})}{\text{Engine RPM}}$$

$$\text{Torque (Nm)} = 1.356 \times \text{Torque (ft-lb)}$$

HOW TO MEASURE: 4

Once you have identified maximum output torque for your application, see the definitions below to determine which description of normal operation best fits your vessel.

Pleasure Craft

Planing hulls where full throttle operation is less than 5% of total operational time. Couplings for these vessels are rated to operate at 85% of maximum allowable working torque.

Medium Duty Craft

Pleasure or commercial craft (planing, semi-displacement or multi-hulls) such as patrol boats, charter fishing boats, etc. Couplings for these vessels are rated to operate at 75% of maximum allowable working torque.

Heavy Duty Craft

Commercial craft (heavy displacement, semi-displacement or multi-hulls in commercial operation) such as trawlers, ferries, etc. Couplings for these vessels are rated to operate at 50% of maximum allowable working torque.

Next, go to the torque charts on pages 11, 13, 15 and 16. Note the torque rating in the chart which matches 1) the IsoFlex coupling that fits your dimensional characteristics and 2) the type of “craft” you operate (given the above descriptions).

If the IsoFlex torque rating in the chart is equal to or higher than the torque rating produced by your drive train, you can now order your GEARguard coupling.

If the IsoFlex torque rating in the chart is lower than the torque rating produced by your drive train, please contact IsoFlex or your local distributor. IsoFlex may be able to produce a High Torque (HT) coupling for your installation.

GEARguard

FLEX COUPLINGS

GENERAL COMMENTS

Bolt Assembly Torque Guide & High Tensile Grades

Coupling bolt size	Recommended assembly torque		High Tensile Grade	
	Ft-lbs	Nm	Imperial	Metric
8mm	10	14		8.8
10mm	31	42		8.8
12mm	34	46		10.9
14mm	60	85		10.9
16mm	83	112		10.9
20mm	150	200		10.9
3/8"	20	27	Grade 5	
7/16"	32	43	Grade 5	
1/2"	47	63	Grade 8	
3/4"	155	210	Grade 8	
7/8"	206	278	Grade 8	
1"	250	338	Grade 8	

NOTE:
Over-tensioning ANY of the bolts during assembly (see torque charts above and on page 29 for guidelines) may cause internal damage to the IsoFlex coupling. In extreme cases, the steel inserts may become distorted or spin within the coupling. The result is a coupling that will not function properly.

Dimensions

As gearbox manufacturers' dimensions and specifications are subject to change, it is necessary to check all dimensions to ensure fit and suitability of the coupling. All IsoFlex couplings are manufactured from engineering grade polymers. Although these materials are thermoset polymers, there may be dimensional changes from those specified, depending upon ambient temperature conditions.

Tolerances

The tolerance on all IsoFlex machined index rings is $\pm 0.002"$ ($\pm 0.05\text{mm}$) @ 25°C (77° F) ambient temperature.

All other dimensions: $\pm 0.020"$ ($\pm 0.5\text{mm}$) @ 25°C (77° F) ambient temperature.

INSTALLATION NOTE: Electrical Isolation

The IsoFlex GEARguard couplings electrically isolate the propeller shaft from the engine and gearbox. If you wish to connect the shaft to the engine, an internal coil spring (option available through IsoFlex) may be fitted.

NOTE: T-Bushings

In the charts on page 12, the couplings marked in red are sold with T-bushings sized to fit the bolt holes in the gearbox / propeller shaft flanges.

In some instances, the size of the original bolts used to connect the gearbox flange and the propeller shaft flange are too large to fit within the space constraints of the bolt circle diameter of the IsoFlex flexible couplings. Flexible couplings require twice the number of bolts than the original installation to accommodate the flanges on either side of the coupling.

When this occurs, IsoFlex (per industry guidelines) reduces the diameter size of its assembly bolts. These high-tensile yet smaller diameter replacement bolts will fit loosely within the existing bolt holes of each flange. Accordingly, IsoFlex provides steel, zinc-plated T-bushings to insert in the holes of both flanges. This approach assures that the smaller diameter, high-tensile assembly bolts fit snugly in each flange.

GEARguard

COUPLINGS



4 BOLT - DIMENSIONS

Imperial							
MODEL	GEARBOX FLANGE BOLT CIRCLE DIAMETER	GEARBOX FLANGE BOLT SIZE	GEARBOX FLANGE INDEX RING TYPE	GEARBOX FLANGE INDEX RING DIAMETER	ISOFLEX COUPLING OUTSIDE DIAMETER	ISOFLEX COUPLING INSIDE DIAMETER	ISOFLEX COUPLING THICKNESS
IFC-4200-90	3.07	10mm	F	1.97	4.92	1.38	0.98
IFC-4300-95	3.25	3/8"	F	2.50	4.92	1.38	0.98
IFC-4400-95	3.94	10mm	F	2.56	5.71	1.97	0.98
IFC-4500-95	4.25	7/16"	F	2.50	5.91	1.77	1.13
IFC-4500-HT	4.25	7/16"	F	2.50	5.91	1.77	1.13
IFC-4500-IV-HT	4.25	7/16"	F	2.50	5.91	2.12	1.42
IFC-4550-95	4.25	7/16"	F	2.50	5.91	1.77	1.13
IFC-4550-HT	4.25	7/16"	F	2.50	5.91	1.77	1.13
IFC-4600-95	3.15	10mm	M	2.36	4.92	1.38	0.98
IFC-4700-95	3.75 (Rect)	7/16"	F	2.75	5.31	1.97	1.26
IFC-4800-95	3.125 (Rect)	3/8"	F	2.38	4.92	1.38	0.98
IFC-4900-95	4.75 (Rect)	1/2"	F	3.75	6.89	1.97	1.44

Metric							
MODEL	GEARBOX FLANGE BOLT CIRCLE DIAMETER	GEARBOX FLANGE BOLT SIZE	GEARBOX FLANGE INDEX RING TYPE	GEARBOX FLANGE INDEX RING DIAMETER	ISOFLEX COUPLING OUTSIDE DIAMETER	ISOFLEX COUPLING INSIDE DIAMETER	ISOFLEX COUPLING THICKNESS
IFC-4200-90	78.00	10mm	F	50.00	125.00	35.00	25.00
IFC-4300-95	82.55	3/8"	F	63.50	125.00	35.00	25.00
IFC-4400-95	100.00	10mm	F	65.00	145.00	50.00	25.00
IFC-4500-95	107.95	7/16"	F	63.50	150.00	45.00	28.60
IFC-4500-HT	107.95	7/16"	F	63.50	150.00	45.00	28.60
IFC-4500-IV-HT	107.95	7/16"	F	63.50	150.00	54.00	36.00
IFC-4550-95	107.95	7/16"	F	63.50	150.00	45.00	28.60
IFC-4550-HT	107.95	7/16"	F	63.50	150.00	45.00	28.60
IFC-4600-95	80.00	10mm	M	60.00	125.00	35.00	25.00
IFC-4700-95	95.25 (Rect)	7/16"	F	69.85	135.00	50.00	32.00
IFC-4800-95	79.38 (Rect)	3/8"	F	60.33	125.00	35.00	25.00
IFC-4900-95	120.65 (Rect)	1/2"	F	95.25	175.00	50.00	36.50

GEARguard

COUPLINGS

4 BOLT - WORKING TORQUE RATINGS

Imperial (ft-lb)

MODEL	HEAVY DUTY	MEDIUM DUTY	PLEASURE CRAFT
IFC-4200-90	360	540	615
IFC-4300-95	360	540	615
IFC-4400-95	360	540	615
IFC-4500-95	490	725	830
IFC-4500-HT	855	1280	1445
IFC-4500-IV-HT	855	1280	1445
IFC-4550-95	315	470	535
IFC-4550-HT	650	975	1105
IFC-4600-95	270	405	465
IFC-4700-95	435	650	725
IFC-4800-95	225	335	380
IFC-4900-95	870	1300	1445

Metric (Nm)

MODEL	HEAVY DUTY	MEDIUM DUTY	PLEASURE CRAFT
IFC-4200-90	500	750	850
IFC-4300-95	500	750	850
IFC-4400-95	500	750	850
IFC-4500-95	675	1000	1150
IFC-4500-HT	1180	1770	2000
IFC-4500-IV-HT	1180	1770	2000
IFC-4550-95	435	650	740
IFC-4550-HT	900	1350	1530
IFC-4600-95	375	560	640
IFC-4700-95	600	900	1000
IFC-4800-95	310	465	525
IFC-4900-95	1200	1800	2000

GEARguard

COUPLINGS



6 BOLT - DIMENSIONS

Imperial							
MODEL	GEARBOX FLANGE BOLT CIRCLE DIAMETER	GEARBOX FLANGE BOLT SIZE	GEARBOX FLANGE INDEX RING TYPE	GEARBOX FLANGE INDEX RING DIAMETER	ISOFLEX COUPLING OUTSIDE DIAMETER	ISOFLEX COUPLING INSIDE DIAMETER	ISOFLEX COUPLING THICKNESS
IFC-6000-95	3.88	7/16"	M	2.50	5.91	1.97	1.25
IFC-6000-HT	3.88	7/16"	M	2.50	5.91	1.97	1.25
IFC-6100-95	4.75	1/2" UNC	M	3.00	6.30	2.36	1.50
IFC-6100-IV	4.75	1/2"	M	3.00	6.30	2.36	1.50
IFC-6125-95	4.75	1/2" UNC	F	3.00	6.30	2.36	1.50
IFC-6150-95	4.75	16mm SHCS	M	3.00	6.30	2.36	1.50
IFC-6150-HT	4.75	16mm SHCS	M	3.00	6.30	2.36	1.50
IFC-6150-IV	4.75	16mm SHCS	M	3.00	6.30	2.36	1.50
IFC-6155-95	4.75	7/16"	M	3.00	160.00	2.36	1.50
IFC-6155-HT	4.75	7/16"	M	3.00	160.00	2.36	1.50
IFC-6300-95	6.00	16mm SHCS	M	3.75	8.35	2.87	1.50
IFC-6300-IV	6.00	16mm SHCS	M	3.75	8.35	2.87	1.50
IFC-6400-95	6.00	16mm SHCS	M	3.75	7.68	2.87	1.50
IFC-6400-HT	6.00	16mm SHCS	M	3.75	7.68	2.87	1.50
IFC-6500-95*	10.24	3/4" UNC	M	6.69	12.99	3.74	1.77
IFC-6600-95*	8.07	16mm SHCS	M	5.12	10.24	3.74	1.50
Metric							
MODEL	GEARBOX FLANGE BOLT CIRCLE DIAMETER	GEARBOX FLANGE BOLT SIZE	GEARBOX FLANGE INDEX RING TYPE	GEARBOX FLANGE INDEX RING DIAMETER	ISOFLEX COUPLING OUTSIDE DIAMETER	ISOFLEX COUPLING INSIDE DIAMETER	ISOFLEX COUPLING THICKNESS
IFC-6000-95	98.43	7/16"	M	63.50	150.00	50.00	31.75
IFC-6000-HT	98.43	7/16"	M	63.50	150.00	50.00	31.75
IFC-6100-95	120.65	1/2" UNC	M	76.20	160.00	60.00	38.10
IFC-6100-IV	120.65	16mm SHCS	M	76.20	160.00	60.00	38.10
IFC-6125-95	120.65	1/2" UNC	F	76.20	160.00	60.00	38.10
IFC-6150-95	120.65	16mm SHCS	M	76.20	160.00	60.00	38.10
IFC-6150-HT	120.65	16mm SHCS	M	76.20	160.00	60.00	38.10
IFC-6100-HT	120.65	16mm SHCS	M	76.20	160.00	60.00	38.10
IFC-6150-IV	120.65	16mm SHCS	M	76.20	160.00	60.00	38.10
IFC-6155-95	120.65	16mm SHCS	M	76.20	160.00	60.00	38.10
IFC-6155-HT	120.65	16mm SHCS	M	76.20	160.00	60.00	38.10
IFC-6300-95	152.40	16mm SHCS	M	95.25	212.00	73.00	38.10
IFC-6300-IV	152.40	16mm SHCS	M	95.25	212.00	73.00	38.10
IFC-6400-95	152.40	16mm SHCS	M	95.25	195.00	73.00	38.10
IFC-6400-HT	152.40	16mm SHCS	M	95.25	195.00	73.00	38.10
IFC-6500-95*	260.00	3/4" UNC	M	170.00	330.00	95.00	45.00
IFC-6600-95*	205.00	16mm SHCS	M	130.00	260.00	95.00	38.10

GEARguard

COUPLINGS

6 BOLT - WORKING TORQUE RATINGS

Imperial (ft-lb)

MODEL	HEAVY DUTY	MEDIUM DUTY	PLEASURE CRAFT
IFC-6000-95	670	990	1140
IFC-6000-HT	980	1460	1700
IFC-6100-95	2250	3350	3800
IFC-6100-IV	2250	3350	3800
IFC-6125-95	2250	3350	3800
IFC-6150-95	2250	3350	3800
IFC-6150-IV	2250	3350	3800
IFC-6155-95	2250	3350	3800
IFC-6300-95	2600	3900	4430
IFC-6300-IV	2600	3900	4430
IFC-6400-95	2170	3250	3700
IFC-6400-HT	3280	4780	5400
IFC-6500-95	6470	9700	Use Medium
IFC-6600-95	4340	6500	Use Medium

Metric (Nm)

MODEL	HEAVY DUTY	MEDIUM DUTY	PLEASURE CRAFT
IFC-6000-95	925	1375	1575
IFC-6000-HT	1350	2020	2350
IFC-6100-95	3050	4575	5175
IFC-6100-IV	3050	4575	5175
IFC-6125-95	3050	4575	5175
IFC-6150-95	3050	4575	5175
IFC-6150-IV	3050	4575	5175
IFC-6155-95	3050	4575	5175
IFC-6300-95	3600	5400	6120
IFC-6300-IV	3600	5400	6120
IFC-6400-95	3000	4500	5100
IFC-6400-HT	4400	6600	7480
IFC-6500-95	8950	13400	Use Medium
IFC-6600-95	6000	9000	Use Medium

GEARguard

COUPLINGS



8 BOLT - DIMENSIONS

Imperial							
MODEL	GEARBOX FLANGE BOLT CIRCLE DIAMETER	GEARBOX FLANGE BOLT SIZE	GEARBOX FLANGE INDEX RING TYPE	GEARBOX FLANGE INDEX RING DIAMETER	ISOFLEX COUPLING OUTSIDE DIAMETER	ISOFLEX COUPLING INSIDE DIAMETER	ISOFLEX COUPLING THICKNESS
IFC-8100-95	7.50	16mm SHCS	M	6.00	10.83	3.74	1.50
IFC-8100-HT	7.50	16mm SHCS	M	6.00	10.83	3.74	1.50
IFC-8200-95	7.50	16mm SHCS	M	6.00	9.53	3.74	1.50
IFC-8200-HT	7.50	16mm SHCS	M	6.00	9.53	3.74	1.50
IFC-8300-95	6.00	16mm SHCS	M	3.75	7.68	2.87	1.50
IFC-8400-95	7.87	16mm SHCS	M	4.33	10.83	2.95	1.50
IFC-8400-HT	7.87	16mm SHCS	M	4.33	10.83	2.95	1.50
IFC-8534-95	8.75	3/4" UNC	M	5.00	12.40	2.95	1.77
IFC-8600-95	9.06	20mm	M	5.91	12.40	3.94	1.77
IFC-8690-95	9.00	3/4" UNC	M	6.00	11.81	3.74	1.77
IFC-8695-95	9.50	3/4" UNC	M	6.00	12.99	3.74	1.77
IFC-8695-HT	9.50	3/4" UNC	M	6.00	12.99	3.74	1.77
IFC-8700-95	11.02	7/8" UNC	F	7.87	13.98	2.95	1.97
IFC-8800-95	13.39	1" UNC	M	7.09	17.91	5.12	2.36
IFC-8900-95	11.80	7/8" UNC	M	7.09	15.75	5.12	1.97

Metric							
MODEL	GEARBOX FLANGE BOLT CIRCLE DIAMETER	GEARBOX FLANGE BOLT SIZE	GEARBOX FLANGE INDEX RING TYPE	GEARBOX FLANGE INDEX RING DIAMETER	ISOFLEX COUPLING OUTSIDE DIAMETER	ISOFLEX COUPLING INSIDE DIAMETER	ISOFLEX COUPLING THICKNESS
IFC-8100-95	190.50	16mm SHCS	M	152.40	275.00	95.00	38.10
IFC-8100-HT	190.50	16mm SHCS	M	152.40	275.00	95.00	38.10
IFC-8200-95	190.50	16mm SHCS	M	152.40	242.00	95.00	38.10
IFC-8200-HT	190.50	16mm SHCS	M	152.40	242.00	95.00	38.10
IFC-8300-95	152.40	16mm SHCS	M	95.25	195.00	73.00	38.10
IFC-8400-95	200.00	16mm SHCS	M	110.01	275.00	75.00	38.10
IFC-8400-HT	200.00	16mm SHCS	M	110.01	275.00	75.00	38.10
IFC-8534-95	222.25	3/4" UNC	M	127.00	315.00	75.00	45.00
IFC-8600-95	230.00	20mm	M	150.01	315.00	100.00	45.00
IFC-8690-95	228.60	3/4" UNC	M	152.40	300.00	95.00	45.00
IFC-8695-95	241.30	3/4" UNC	M	152.40	330.00	95.00	45.00
IFC-8695-HT	241.30	3/4" UNC	M	152.40	330.00	95.00	45.00
IFC-8700-95	280.00	7/8" UNC	F	200.00	355.00	75.00	50.00
IFC-8800-95	340.00	1" UNC	M	180.01	455.00	130.00	60.00
IFC-8900-95	300.00	7/8" UNC	M	180.00	400.00	130.00	50.00

GEARguard

COUPLINGS

8 BOLT - WORKING TORQUE RATINGS

Imperial (ft-lb)

MODEL	HEAVY DUTY	MEDIUM DUTY	PLEASURE CRAFT
IFC-8100-95	4950	7430	Use Medium
IFC-8100-HT	6150	9220	Use Medium
IFC-8200-95	3250	4880	Use Medium
IFC-8200-HT	5700	8570	Use Medium
IFC-8300-95	2170	3250	3700
IFC-8400-95	5060	7600	Use Medium
IFC-8400-HT	7600	11400	Use Medium
IFC-8500-95	6150	9220	Use Medium
IFC-8534-95	6150	9220	Use Medium
IFC8600-95	6250	9380	Use Medium
IFC-8690-95	6250	9380	Use Medium
IFC-8695-95	6500	9770	Use Medium
IFC-8695-HT	9650	14500	Use Medium
IFC-8700-95	7250	10850	Use Medium
IFC-8800-95	16300	24500	Use Medium
IFC-8900-95	13200	20000	Use Medium

Metric (Nm)

MODEL	HEAVY DUTY	MEDIUM DUTY	PLEASURE CRAFT
IFC-8100-95	6850	10275	Use Medium
IFC-8100-HT	8500	12750	Use Medium
IFC-8200-95	4500	6750	Use Medium
IFC-8200-HT	7900	11850	Use Medium
IFC-8300-95	3000	4500	5100
IFC-8400-95	7000	10500	Use Medium
IFC-8400-HT	8500	12750	Use Medium
IFC-8500-95	8500	12750	Use Medium
IFC-8534-95	8500	12750	Use Medium
IFC8600-95	8650	12975	Use Medium
IFC-8690-95	8650	12975	Use Medium
IFC-8695-95	9000	13500	Use Medium
IFC-8695-HT	13350	20100	Use Medium
IFC-8700-95	10000	15000	Use Medium
IFC-8800-95	22500	33750	Use Medium
IFC-8900-95	18300	27500	Use Medium

GEARguard

COUPLINGS

10 BOLT - DIMENSIONS

Imperial							
MODEL	BOLT CIRCLE DIAMETER	SIZE OF BOLTS	INDEX RING TYPE	INDEX RING DIAMETER	GEARBOX FLANGE OUTSIDE DIAMETER	GEARBOX FLANGE INSIDE DIAMETER	ISOFLEX PART THICKNESS
IFC-10325-HT	6.69	14mm SHCS	M	5.51	8.35	2.95	1.77
0.70" T-bushing included							
Metric							
IFC-10325-HT	170.00	14mm SHCS	M	140.00	212.00	75.00	45.00
18mm T-bushing included							

10 BOLT - WORKING TORQUE RATINGS

Imperial (ft-lb)			
MODEL	HEAVY DUTY	MEDIUM DUTY	PLEASURE CRAFT
IFC-10325-HT	3600	5400	6150
Metric (Nm)			
IFC-10325-HT	5000	7500	8500

SPICER U JOINT

FLANGE FLEX COUPLINGS



DIMENSIONS

Imperial								
COUPLING	PCD (INS)	NO & SIZE OF BOLTS NXD	SPIGOT (INS)	FLANGE TYPE	OD (INS)	ID (INS)	THICKNESS (INS)	WEIGHT INCL. BOLT SET (lb)
IFC4700(95)	3.75	4 x 7/16" rect	2.75	F	5.315	1.969	1.3	3.1
IFC4800(95)	3.13	4 x 7/16" rect	2.38	F	4.921	1.378	1	1
IFC4900(95)	4.75	4 x 1/2" rect	3.38	F	6.89	1.969	1.4	1.4
IFC81610 HT	6.13	8 x 3/8"	6.63	F	8.66	1.969	1	1
IFC81710 HT	7.25	8 x 3/8"	7.75	F	9.49	2.93	1.2	1.2

Metric								
COUPLING	PCD (MM)	NO & SIZE OF BOLTS NXD	SPIGOT (MM)	FLANGE TYPE	OD (MM)	ID (MM)	THICKNESS (MM)	WEIGHT INCL. BOLT SET (kg)
IFC4700(95)	95.25	4 x 7/16" rect	69.85	F	135	50	32	1.4
IFC4800(95)	79.38	4 x 7/16" rect	60.33	F	125	35	25	1
IFC4900(95)	120.65	4 x 1/2" rect	85.73	F	175	50	36.5	2
IFC81610 HT	155.7	8 x 3/8"	168.28	F	220	50	25	2
IFC81710 HT	184.15	8 x 3/8"	196.86	F	241	74.4	30	2.4

APPLICATIONS

SPICER FLANGE	COUPLING	SHORE A
1310	IFC4800	95
1350	IFC4700	95
1410	IFC4700	95
1410	IFC4700	HT
1480	IFC4900	95
1510	IFC4900	95
1550	IFC4900	95
1610	IFC81610	95
1710	IFC81710	95
1710	IFC81710	HT

COUPLING CROSS REFERENCE

GLOBE DRIVESAVER TO ISOFLEX

DRIVESAVER	ISOFLEX	COMMENTS
303	n/a	
353	n/a	
354	n/a	
404	n/a	
404A	IFC-4300-95	
404AC	IFC-4300-95	2 5/8" Pilot Req'd
404V	IFC-4600-95	
404S	n/a	
424Y	IFC-4200-95	
4756	IFC-6000-95	
4756PR	IFC-6000-HT	
454	n/a	
504	IFC-4500-95	
504A	n/a	
504AC	n/a	
504PR	IFC-4500-HT	
504H	IFC-4550-95	
504HPR	IFC-4550-HT	
524Y	IFC-4400-95	
554	n/a	
908	IFC-8100-95	Iso 1/2" Thicker
908PR	IFC-8100-95	Iso 1/2" Thicker
908S	IFC-8200-95	Iso 1/2" Thicker
n/a	IFC-8200-HT	Iso 1/2" Thicker
908AC	n/a	

DRIVESAVER	ISOFLEX	COMMENTS
1058	IFC-8534-95	
1108	IFC-8695-95	
1108A	IFC-8690-95	
1308	n/a	
4756	IFC-6000-95	
5756	IFC-6100-95	Male Index Ring
5756A	IFC-6125-95	Female Index Ring
5756APR	IFC-6125-HT	Female Index Ring
5756AZF	IFC-6100-95	Male Index Ring
5756AZFPR	IFC-6100-HT	Male Index Ring
5756B	IFC-6150-95	Iso 16mm Bolts
5756T	IFC-6150-95	No Bushing Kit Req'd
6256	n/a	
7256	IFC-6300-95	
7256PR	IFC-6300-HT	
7258ZPR	n/a	
7306Z	IFC-6400-95	IsoFlex 7mm(0.27") Thicker
8078Z	n/a	
8010Z	IFC-10325-95	IsoFlex 7mm(0.27") Thicker
8858Z	n/a	

ALWAYS CHECK TORQUE RATINGS

COUPLING CROSS REFERENCE

POLY FLEX TO ISOFLEX

POLY FLEX	ISOFLEX	COMMENTS
424(90)	IFC-4200-90	
434(90)/(95)	IFC-4300-95	
464(90)/(95)	IFC-4600-95	
484(90)/(95)	IFC-4800-95	
524(90)/(95)	IFC-4500-95	
524FRL	IFC-4550-95	
534(90)/(95)	IFC-4400-95	
546(95)	IFC-6000-95	
547(90)/(95)	IFC-4700-95	
616-1/2 Bolts-M	IFC-6100-95	
616-1/2 Bolts-F	IFC-6125-95	
616-5/8 Bolts	IFC-6150-95	
656	IFC-6150-95	
1550	IFC-4900-95	
2308	IFC-8600-95	
2808	IFC-8700-95	
3408	IFC-8800-95	

POLY FLEX	ISOFLEX	COMMENTS
7206-5/8 Bolts	IFC-6300-95	
7206-3/4 Bolts	IFC-6300-95	ITBK-19-6B
7606	IFC-6400-95	
7606-3/4 Bolts	IFC-6400-95	ITBK-19-6B
7608	IFC-8300-95	
9114	IFC-8200-95	ITBK-22-8B
9114 3+3 IRM	IFC-8200-95	
9858 5/8	IFC-8100-95	ITBK-22-8B
9858 3/4	IFC-8100-95	ITBK-22-8B
9934	IFC-8400-95	
10834	IFC-8534-95	
11834A	IFC-8690-95	
11834	IFC-8695-95	

ALWAYS CHECK TORQUE RATINGS

COUPLING CROSS REFERENCE

R&D TO ISOFLEX

R&D	ISOFLEX	COMMENTS	ISOFLEX COUPLING THINNER BY INCHES
RA900-003	IFC-6000-95		
910-001	IFC-4300-95		0.30
910-002	IFC-4200-95		0.30
910-005	IFC-4300-95	Special Index Ring	0.37
910-006	IFC-6150-95		0.37
910-007	IFC-4600-95		0.74
910-009	IFC-4500-95		0.65
910-012	IFC-4400-95		0.79
910-013	n/a		n/a
910-014	IFC-4300-95		0.30
910-015	n/a		n/a
910-016	n/a		n/a
910-017	IFC-6400-95	ITBK-19-6B	0.89
910-018	IFC-6400-95		0.89
910-019	IFC-4600-95		0.30
910-020	IFC-4600-95		0.30
910-021	n/a		n/a
910-022	IFC-8200-95	ITBK-22-8B	0.25
910-024	IFC-8534-95	ITBK-25-8B	0.46
910-025	IFC-6100-95	Male Index Ring	0.46
	OR		
	IFC-6125-95	Female Index Ring	0.68
910-026	IFC-6150-95		0.46
910-027	n/a		0.00
910-028	n/a		0.00
910-029	IFC-4500-HT		0.94
910-030	n/a		n/a
910-032	IFC-6125-95/a	Female Index Ring	0.68

R&D	ISOFLEX	COMMENTS	ISOFLEX COUPLING THINNER BY INCHES
910-033	IFC-6150-95		0.68
910-034	IFC-4500-95		0.65
910-035	n/a		n/a
910-036	n/a		n/a
910-037	IFC-4500-95		0.89
910-038	n/a		n/a
910-039	IFC-6400-95	ITBK-19-6B	0.99
910-040	IFC-6400-95		0.99
910-041	n/a		n/a
910-042	n/a		n/a
910-043	IFC-4200-90		0.30
910-044	IFC-4500-95		0.65
910-045	n/a		n/a
910-046	IFC-8100-95	ITBK-22-8B	0.25
910-047	n/a		n/a
910-048	IFC-8100-95	ITBK-22-8B	0.97
910-049	n/a		n/a
910-050	IFC-8200-95	ITBK-22-8B	2.50
910-051	IFC-8695-95		0.53
910-052	IFC-6000-95		1.49
910-053	n/a		n/a
910-054	IFC-6100-95	Male Index Ring	0.37
	OR		
	IFC-6125-95	Female Index Ring	0.68
910-055	IFC-4300-95		0.79
910-057	IFC-4500-HT		0.94
910-058	n/a		n/a
910-059	IFC-4600-95		0.42

ALWAYS CHECK TORQUE RATINGS

NOTE: Due to design parameters, R&D Couplings are usually quite a bit thicker than the comparable IsoFlex GEARguard Coupling. Please note these differences in the chart above before ordering. Installing the IsoFlex GEARguard Coupling may require other modifications to drive line components.

TRANSMISSION CROSS REFERENCE

TWIN DISC TO ISOFLEX

TWIN DISC	ISOFLEX COUPLING	COMMENTS
MG340, MG360, MG5010SC, MG5011SC, MG5010V	IFC-4300-95	
MG5005A, MG5012C, MG5015A, MG5020SC and MG5055A	IFC-4500-HT	
MG502-1, 502, 502A, 502V	IFC-6000-95	
MG506, 506-1, 506-1A, 5065C, 5061, 5061A, 5062V	IFC-6150-95 OR IFC-6300-95	+ Adaptor
MG506DC	IFC-6400-95	
MG507, MG507A-1 w/ 6" Flange	IFC-6150-95	
MG507, MG507A-1 w/ 7 1/4" Flange	IFC-6400-95	ITBK-19-6B
MG507SC	IFC-6150-95	ITBK-19-6B
MG507-2, MG507A-2	IFC-6400-95	ITBK-19-6B
MG509SC	IFC-6400-95	ITBK-19-6B
MG509DC, MG509CP	IFC-8534-95	
MG510, MG510A, MG510SC	IFC-8100-95 OR IFC-8534-95	ITBK-22-8B + Adaptor
MG510DC	IFC-8534-95	ITBK-25-8B
MG511, MG512, MG513, MG514SC	IFC-8534-95	ITBK-25-8B
MG514DC, MG516DC MG518, MG520, MG530, MG540	Contact IsoFlex	
MG5010A, MG5011A and MG5011SC	Contact IsoFlex	+ Adaptor
MG5010DC, MG5050V	IFC-6150-95	
MG5050A, MG5050SC	IFC-6150-95	
MG5050	IFC-6150-95	+ Adaptor

TWIN DISC	ISOFLEX COUPLING	COMMENTS
MG5061A, MG1061SC, MG5062V	IFC-6150-95	
MG5065A, MG5065SC	IFC-6400-95	ITBK-19-6B
MG5075A 6" Flange	IFC-6150-95	
MG5075A with 7 1/4" Flange	IFC-6400-95	ITBK-19-6B
MG5075SC	IFC-6400-95	ITBK-19-6B
MG5081, 5081A, MG5082A and MG5082SC	IFC-6400-95 OR IFC-8100-95	ITBK-19-6B ITBK-22-8B
MG 5085, 5085A, 5085SC, MG 5090A, 5091, 5091A	IFC-6400-95 OR IFC-8100-95	ITBK-19-6B ITBK-22-8B
MG5095A, MGX5095A	IFC-6400-95	Plus Special ITBK-20-6B
MG5091DC, MG509DC, MG5111DC, MG5114DC, MG5113 and MG514DC	IFC-8534-95	ITBK-25-8B
MG5111SC, 5111A, MGX5114IV	IFC-8100-95	ITBK-22-8B
MG5114A, MG514C	IFC-8200-95	ITBK-22-8B
MG5114SC	IFC-8200-95	ITBK-22-8B
MG5114DC	IFC-8100-95	ITBK-22-8B
MG5135A, MG5136A	IFC-8100-95	ITBK-22-8B
MG5135SC	IFC-8100-95	ITBK-19-6B
MG5141SC	IFC-8200-95	ITBK-25-8B
MG5145A, MGX5145A, MG5146A, MGX5147A	IFC-8400-95	ITBK-24-8B
MGX5146DC	IFC-8534-95	+ Adaptor
MGX5095A	IFC-6400-95	Plus Special ITBK-20-6B
MG5202SC	IFC-8690-95	ITBK-24-8B

Twin Disc Note: Check torque ratings, especially on commercial applications. Bolt lengths may vary on the MGX transmission models as the pick-up ring on flange dictates. MG5081 may have interference from oil pump - check with IsoFlex.

TRANSMISSION CROSS REFERENCE

ZF TO ISOFLEX

ZF	ISOFLEX COUPLING	COMMENTS
5M, 10M, 12, 12M, 15M, 15MA, 15MIV, 25M, 25MA, 30M, 25 and 25A	IFC-4300-95	
45A, 450D, 45C w/ 4" Flange	IFC-4300-95	
41, A2/A3, 45A	IFC-4550-HT	
50A2/A3, 63, 63A/IV, HSW630V, ZF901VTS	IFC-4500-95	or IFC-4500-HT
HSW800A2, HSW800A3 and 45-1 with 6" Flange	IFC-6125-95	
80A, 85, 85A, 85IV	IFC-6150-95	
220A	IFC-6000-95	
220V	IFC-6300-95	
HSW220V-2, 800V1, 800V2, ZF1101VTS, 220IV, 80IV and 80-1IV	IFC-6100-95	
280IV, 280-1, 280-1A, 285A, 285IV, 286IV, 301A and 301C	IFC-6150-95	
HSW800A2, HSW800A3, 280A and 280	IFC-6150-95	
220	IFC-6150-95	Spacer Required
300TS, 300-ITS, 300ATS, 300-IATS, 300VTS, 110ATS and 110IVTS	IFC-6150-95	
220PL, 280V-LD, 280PL, 301PL-2 and 301A-2	IFC-6150-95	

ZF	ISOFLEX COUPLING	COMMENTS
302IV, 304A, 304C, 305-1	IFC-8300-95	
305-2, 305-2A (10 Bolt)	IFC-6300-95	+ Adaptor
311, 311A - Using 8 Bolt Flange	IFC-8300-95	
302, 310, 311, 311A - all using a 10-Bolt Flange	IFC-6300-95	+ Adaptor
320, 320A, 320PL	IFC-8500-95	+ Adaptor
325-1, 325-1A - 10 Bolt	IFC-10325-HT	
325-1, 325-1A - 12 Bolt	IFC-8200-95	+ Adaptor
350, 350A, 350V - 10 Bolt	IFC-10325-HT	
350, 350A, 350V - 12 Bolt	IFC-8100-95	+ Adaptor
350, 350A, 350IV, 350V (8 Bolt)	IFC-8100-95	+ Adaptor
360, 360A - 10 Bolt	IFC-10325-HT	
360, 360A - 12 Bolt	IFC-8200-95	+ Adaptor
500A, 500IV	IFC-10325-HT	
510A, 510V	IFC-10325-HT	
550, 550A, 550V, 550TS	IFC-10325-HT	
665, 665A, 665V, 665TS	IFC-10325-HT	+ Adaptor
2000, 2000A, 2000V	Contact IsoFlex	
2050, 2050A, 2050V	Contact IsoFlex	

Notes: Check torque in commercial applications. Flanges may vary depending on package or factory of origin's variations. New ZF25A may interfere with oil pump - IsoFlex coupling requires OD machining.

TRANSMISSION CROSS REFERENCE

OTHER MANUFACTURERS

MANUFACTURER/ MODEL	ISOFLEX COUPLING	COMMENTS
ALLISON		
Allison M25	IFC-8100-95	ITBK-19-8B?
Allison M11, 15, 17, 20	IFC-6300-95	
Allison MH	IFC-8100-95	ITBK-19-8B?
BORG WARNER		
BW70C	IFC-4300-95	
BW71C 4"	IFC-4300-95	
BW500	IFC-4300-95	
BW1000	IFC-4300-95	
BW1500	IFC-4300-95	
BW71C 5"	IFC-4500-95	
BW72C 5"	IFC-4500-95	
BW VELVET DRIVE 5000A	IFC-4500-95	
BW73C 6"	IFC-6100-95	
BW 7000 SERIES	IFC-6100-95	
NOTE: Borg Warner is now part of ZF Group		
CAPITOL		
7700 and many others	IFC-8100-95	
HARDY SPICER		
SHAFT		
1310	IFC-4800-95	
1350	IFC-4700-95	
1410	IFC-4700-95	
1480	IFC-4900-95	
1510	IFC-4900-95	
1550	IFC-4900-95	
1610	TBA	
1710	TBA	
HURTH		
HBW/HSW 5, 10, 35, 40, 50, 100, 125	IFC-4300-95	
HSW 150, 150A, 220, 250	IFC-4300-95	
HSW 360, 360A, 400, 450	IFC-4500-95	450A - may need Adaptor
HSW 600, 630, 630A1, 630H	IFC-4500-95	
HSW 800A	IFC-6100-95	
Note: If the model you are looking for is not here, please check the ZF Cross Reference.		

MANUFACTURER/ MODEL	ISOFLEX COUPLING	COMMENTS
NEWAGE PRM		
101, 140, 160, 260	IFC-4500-90	
175, 265, 310, 401, 402	IFC-6125-95	
601 6" Flange	IFC-6125-95	
1000 6" Flange	IFC-6125-95	
601, 1000 4:1, 1200S, 1500S, 1500S, 1750S - 7 1/4" Flange	IFC-6300-95	
PRM DELTA	IFC-4300-95	
PRM 80	IFC-4300-95	
PRM 120, 150	IFC-4300-95	
PRM 260, 500	IFC-6125-95	
PRM 750	IFC-6125-95	
PRM 1000	IFC-6150-95	
PRM 1200D, 1500D, 1750D	IFC-8534-95 + 1" Bushing Kit	
PRM 1000 DROP CENTRE 4:1	IFC-6300-95	
NICO NAGATA		
MGN 17B	TBA	
MGN 36	TBA	
MGN 46L	TBA	
MGN 56B	TBA	
MGN 56E	TBA	
MGN 76B1	TBA	
MGN 80E	TBA	
MGN133	TBA	
PARAGON		
4" Flange - 2.63" Spigot Req'd	IFC-4300-SP	
TECHNODRIVE		
TMC30, TM40P, TMC50, TMC60 (All w/ 4" Flange)	IFC-4300-90	
TMC60E	IFC-4300-90	
TM260 4" Flange	IFC-4300-90	
TMC93, 93A	IFC-4500-95	
TMC345, 345A	IFC-4500-90	
TMC485, 545A	IFC-4500-95	
TM170, 170A *	IFC-4500-HT	
TM880A *	IFC-4500-HT	
TM130B,	IFC-6150-95	

TRANSMISSION CROSS REFERENCE

OTHER MANUFACTURERS

MANUFACTURER/ MODEL	ISOFLEX COUPLING	COMMENTS
TECHNODRIVE (CONT.)		
TM260, 265A	IFC-6150-95	
TCM200B	IFC-6400-95	
TM360 **	IFC-8400-95	
TMI200A	IFC-8300-95	
* Check Torque Calculations ** Check Pump Clearance		
VOLVO		
MS, MS2, MS10, MS15, MS25 and RB	IFC-4600-95	
MD10A	IFC-4600-95	
2000 SERIES	IFC-4600-95	
MD7A, 11C, 38	IFC-4600-95	
MS3, MS4, MS4A, MS5	IFC-4500-95	
HS25A, HS45A, HS63A	IFC-4500-HT	
YANMAR / KANSAKI		
YSE8, YSME8, YSBE8, YSEI2, YSMW12, YSBEI2	IFC-4200-90	
20M, 20H, 20G	IFC-4200-90	
JH-2-TF	IFC-4200-90	
1GM10, 2GM20F, 3GM30F, 3HM/3HMSF, 2YM, 3YM, JH3, JH4, 4" FLANGE	IFC-4200-90	
YSM, YSB, SB, 2QM15, 2QM2030M, 30H, 30F, 30G, 4" FLANGE	IFC-4400-95	

MANUFACTURER/ MODEL	ISOFLEX COUPLING	COMMENTS
30M, 30H, 30G 4 3/4" flange	IFC-4200-90	
30M, 30H, 30G 5" flange	IFC-4400-95	
KBW10	IFC-4200-90	
KM2P-1	IFC-4200-90	
KM35A-2, KM2A, KM2C	IFC-4200-90	
KM3A, KM3A1, KM3P (4")	IFC-4200-90	
KM35P	IFC-4200-90	
KBW20, KBW20-1, KBW21	IFC-4400-95	
KM4, KMH4, KMH4A, KMH4A-1, KH18	IFC-4400-95	
KM4A-2	IFC-4400-95	
KM5, KM5A	IFC-4550-95	
KMH40	IFC-4550-95	
KMH50A	IFC-4550-HT	
KMH50V	IFC-4500-HT	
KMH60A/61A	IFC-6155-95	
KMH60V	N/A	
LH SERIES	IFC-4500-95	
YXH160	IFC-6600-95	
YXH180	IFC-6500-95	
YXH240	IFC-6500-95	

Note: KMH50 Transmission can see 1600Nm. Option is to use SAE #3 Flange with IFC-6150-95.

GEARguard INSTALLATION INSTRUCTIONS

GENERAL

THE FOLLOWING “GENERAL” INSTALLATION INSTRUCTIONS COVER THE 4-BOLT, 6-BOLT AND 8-BOLT COUPLINGS. EACH COUPLING SHIPS WITH ITS OWN MODEL-SPECIFIC SET OF INSTRUCTIONS.

STEP 1. CHECK FOR ALIGNMENT

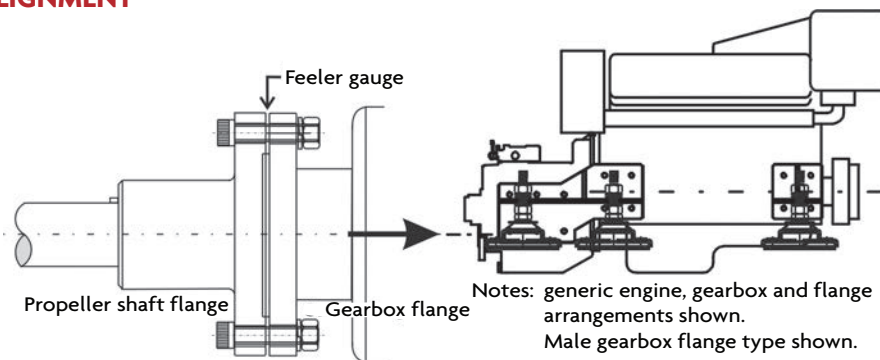

- Check existing alignment of flanges.
- Loosen the gearbox and propeller shaft flange bolts just enough to insert a feeler gauge between the flanges around the entire circumference of the parts.
- Align the flanges (using the adjusting nuts on the engine mounts) to within .003” (.07mm) around the circumference of the flanges.

STEP 2. MEASURE THE INDEXING SURFACES – ISOFLEX COUPLING AND GEARBOX FLANGE

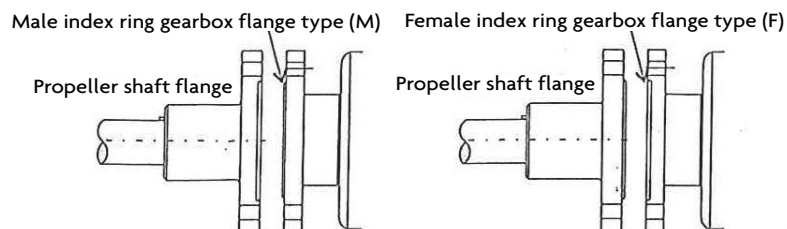

- Remove the flange bolts and separate the flanges from each other to a distance that allows you to position the IsoFlex coupling between the flanges.
- If the gearbox flange has a female index ring, press the male index ring of the IsoFlex coupling into the gearbox flange. The surface of the coupling should fit tightly against the gearbox flange. There should be no visible gaps between the mating surfaces.

GEARguard

INSTALLATION INSTRUCTIONS GENERAL

- Next, press the female index ring of the IsoFlex coupling over the male index ring on the propeller shaft flange. Once again, there should be no visible gaps between the mating surfaces.
- If the IsoFlex coupling “stands away” from either flange in the drive train, the index rings have “bottomed out” which means the coupling will not function correctly. Stop the installation and call IsoFlex or Tides Marine for assistance.

STEP 3. CONNECT GEARGUARD COUPLING TO GEARBOX FLANGE

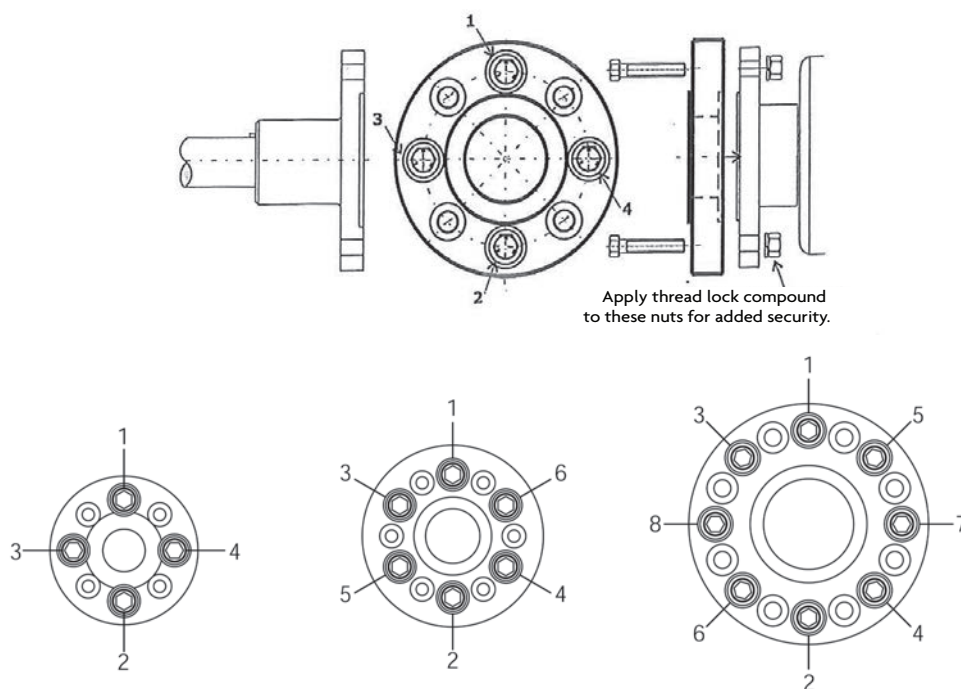

- Hold the IsoFlex coupling against the gearbox flange, mating the index features of both parts. Rotate the coupling to align the countersunk T-bushings in the coupling with the holes in the gearbox flange. Insert the “longer” bolts into the countersunk T-bushings and through the gearbox coupling. Place the lock washers over the bolts and affix the nuts. Apply some sort of thread lock liquid/paste (LOCTITE) to the threads before securing the nuts.
- Tighten these bolts to the required torque in two steps.

4-BOLT COUPLINGS, 6-BOLT COUPLINGS, 8-BOLT COUPLINGS

First, tighten (in the sequence shown in the drawing above) to half of the recommended torque rating for the bolts in your coupling. Then tighten (using this same sequence) to the final recommended torque rating. Lock washers should be fully compressed.

GEARguard

INSTALLATION INSTRUCTIONS GENERAL

STEP 4. CONNECT THE PROPELLER SHAFT FLANGE TO THE GEARGUARD COUPLING

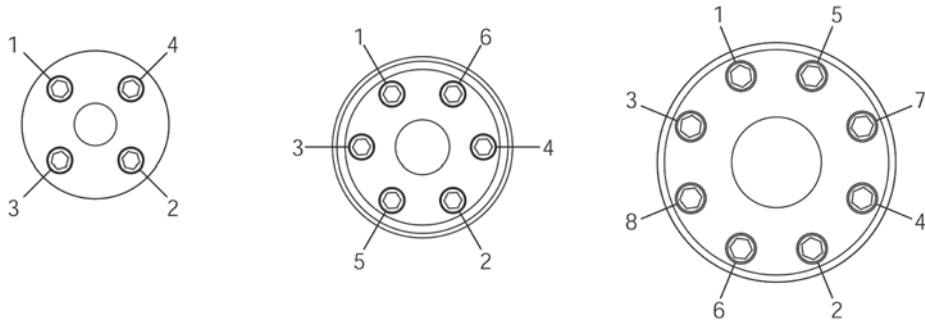
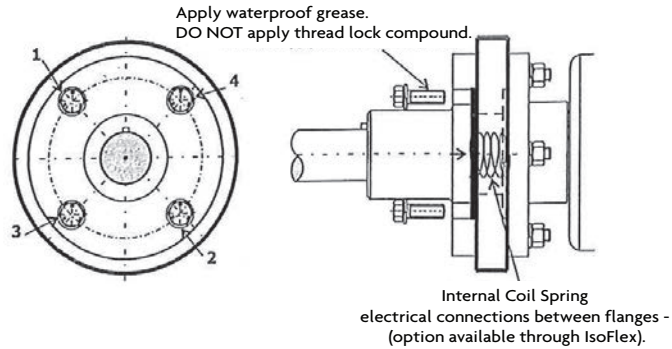

- Fit the propeller shaft flange to the IsoFlex coupling, rotating the propeller flange to align the remaining threaded inserts with the holes in the propeller shaft coupling.
To make it easier to remove the propeller shaft coupling in the future, apply a thin layer of waterproof grease to the threads before securing the bolts into the coupling.
- Place lock washers onto the “shorter” bolts. Insert the bolts (with lock washers) through the propeller shaft coupling and thread into the threaded inserts in the IsoFlex coupling.
- Tighten these bolts to the required torque in two steps.

4-BOLT COUPLINGS, 6-BOLT COUPLINGS, 8-BOLT COUPLINGS

First, tighten (in the sequence shown in the drawing above) to half of the recommended torque rating for the bolts in your coupling. Then tighten (using this same sequence) to the final recommended torque rating. Lock washers should be fully compressed.

NOTE: Over-tensioning ANY of the bolts during assembly (see torque charts on pages 9 and 29 for guidelines) may cause internal damage to the IsoFlex coupling. In extreme cases, the steel inserts may become distorted or spin within the coupling. The result is a coupling that will not function properly.

STEP 5. CHECK FOR RUN-OUT

Slowly rotate the shaft by hand with a dial indicator on the gearbox output flange – then the propeller flange. Run-out of approximately .004” (.01mm) is acceptable for most power transmission applications.

GEARguard

INSTALLATION INSTRUCTIONS

GENERAL

STEP 6. SEA TRIALS

Check the GEARguard coupling for heat build-up after 2 hours of sea trials. If the coupling is noticeably hotter than the gearbox flange (or if bolts have become loose), this is an indication that the flanges are misaligned. This needs to be corrected to avoid any damage to the coupling or other drive line components.

STEP 7. RE-CHECK ASSEMBLY BOLTS IN THE PROPELLER FLANGE.

After approximately 15 hours of operation, re-check the bolts in the propeller shaft flange for torque accuracy.

ADDITIONAL INSTALLATION NOTES

A. Electrical Isolation

The IsoFlex GEARguard couplings electrically isolate the propeller shaft from the engine and gearbox. If you wish to connect the shaft to the engine, an internal coil spring (option available through IsoFlex) may be fitted as shown below.

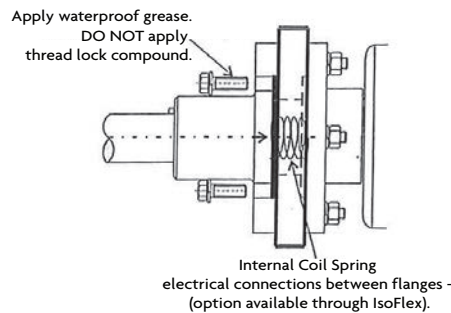

B. Flange Misalignment

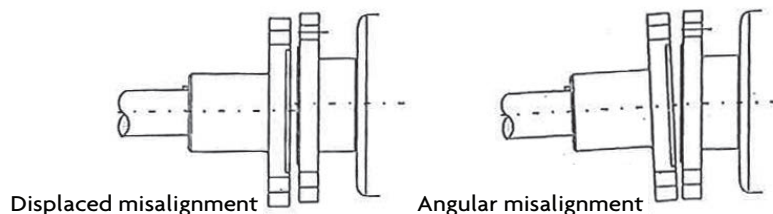

It is very important to check for misalignment of the gearbox and propeller shaft flanges. Both “displaced” and “angular” misalignment can be present in your installation. Please see diagrams above.

These types of misalignment should be minimized (maximum allowable between flanges being .005” or .125mm). Otherwise, service life of the IsoFlex GEARguard coupling will be noticeably reduced.

During normal operation, heat build-up in the coupling is a good indicator that the system is misaligned.

GEARguard INSTALLATION INSTRUCTIONS

GENERAL

C. Adaptors

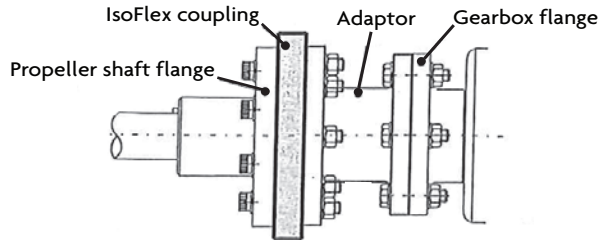

Certain applications require an adaptor (sometimes referred to as a cotton reel or spool) to be fitted to the output flange of the gearbox. This adaptor will 1) move the GEARguard coupling far enough aft to clear any obstructions near the back of the engine (oil pumps, etc.) and 2) permit a different bolt pattern between the output flange and the required coupling.

Please note the diagram in this section.

If your installation requires an adaptor, IsoFlex recommends that it be manufactured by a marine engineering company from 1040 grade steel or equivalent and machined to industry tolerances. Please check carefully for fit and run-out once installed.

D. Dimensions and Tolerances

As gearbox manufacturers' dimensions and specifications are subject to change, it is necessary to check all dimensions to ensure the GEARguard coupling fits and works correctly.

All IsoFlex couplings are manufactured from engineering-grade polymers (thermoplastics). As a result, dimensional changes may occur depending upon ambient operating conditions.

Tolerances on all machined index rings: $\pm .002''$ ($\pm .05\text{mm}$) @ 25° C.

All other dimensions: $\pm .020''$ ($\pm .5\text{mm}$) @ 25°C.

E. Bolt Kits - Recommended Assembly Torque

Coupling Bolt Size	Recommended Assembly Torque		High Tensile Grade AS 2465/ AS1110
	ft-lbs	Nm	
3/8"	20	27	Grade 5 / Class 8.8
7/16"	32	43	Grade 5 / Class 8.8
1/2"	47	63	Grade 8 / Class 10.9
3/4"	155	210	Grade 8 / Class 10.9
7/8"	206	278	Grade 8 / Class 10.9
1"	250	338	Grade 8 / Class 10.9

Coupling Bolt Size	Recommended Assembly Torque		High Tensile Grade AS 2465/ AS1110
	ft-lbs	Nm	
8mm	10	14	Grade 5 / Class 8.8
10mm	31	42	Grade 5 / Class 8.8
12mm	34	46	Grade 8 / Class 10.9
14mm	60	85	Grade 8 / Class 10.9
16mm	83	112	Grade 8 / Class 10.9
20mm	150	200	Grade 8 / Class 10.9

NOTES

NOTES

IsoFlexTM

MINIMIZING

VIBRATION

Authorized Distributor:

IsoFlex Technologies Pty Ltd
Unit 11, 75 Waterway Drive
Gold Coast Marine Precinct
Coomera, Queensland
Australia 4209

Phone +61 7 5556 0924
Fax +61 7 5556 0984
Toll free 1300 366 393
info@isoflex.com.au
isoflex.com.au

IsoFlex Technologies International, LLC
3434 SW 15th Street, Suite B
Deerfield Beach, FL 33442

Phone +1 561-210-5170
Toll free 888-327-9260
info@isoflextech.com
isoflextech.com

ISOFLEX COUPLING AU (Rev. 3/7/18)

GEARguard

FLEX COUPLINGS